

1. Notice

It is used in industry sewing machine. For perfect operation and safety, installation and operation must be supervised by professional.

1.1 Work Environment

- ▲ Please use 220VAC in ±10% ranges.
- ▲ To avoid the false operation please keep the product away from the high electromagnetic interference.
- ▲ Please operate in the area which temperature is 5°C~45°C and humidity is 80% or less.
- ▲ Please keep the product away from the flammability and exploder.

1.2 Notice of Installation

- ▲ Turn off the power and unplug the cord before installation.
- ▲ The wire must not set to be near the wheel and other movable parts.
- ▲ To avoid the static interference and current leakage, all grounding must be done.

1.3 Notice of Safety

- ▲ Turn off the power before maintenance and repairs or raising the machine arm, or changing needle, or threading needle.
- ▲ Please don't open the box except the professional.
- ▲ When turn on the machine in the first time, use low speed to operate and check the correct rotation direction.
- ▲ During machine operation, don't touch any moving parts.
- ▲ All moving parts must use the protective device to avoid the body contact and objects insertion.
- ▲ When there is water or other liquid, or caustic material on box or motor, you must stop operation and turn off the power.
- ▲ All connector shouldn't be plug and unplug when power on.
- ▲ The connector should be plug and unplug in the correct method.

2. Power Connection

2.1 Single Phase 220V Power Connection

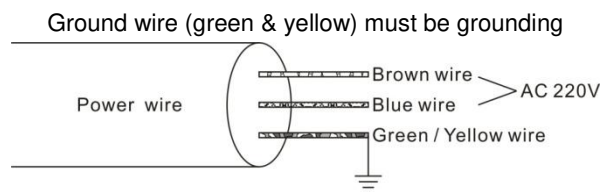

2.2 Three Phase 380V Power Connection

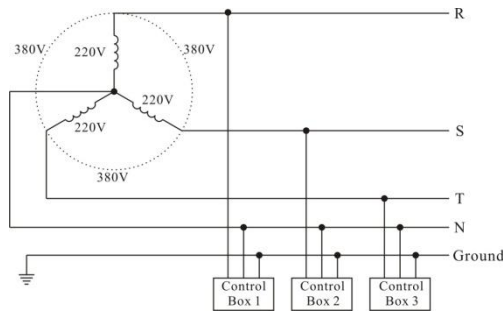

3. Connector Diagram

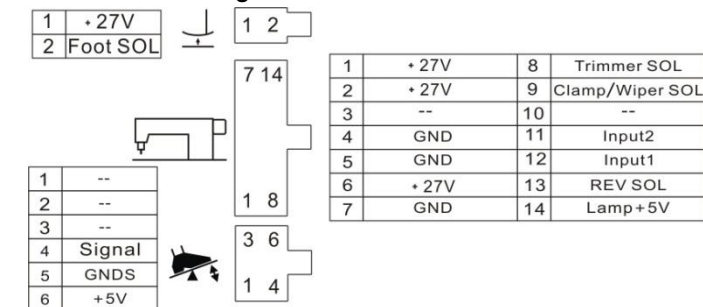

Note: Input1 default is RVS switch, Input2 default is COR switch.

4. Function of Operation Box

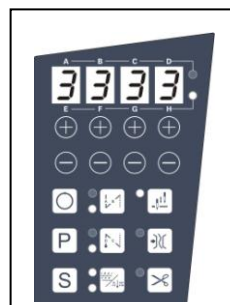

SN.	Key	Operation
1		Start backtack: Top LED set single, bottom LED set double. The number of start backtack stitches (1~15) in the A and B of the display are sewn.
2		End backtack: Top LED set single, bottom LED set double. The number of end backtack stitches (1~15) in the C and D of the display are sewn.
3		Mode: Top LED set Continuous Backtack, bottom LED set Fixed Stitch.
4		Clamp/wiper: See 5.7
5		Needle Up/Down: See 5.3
6		Thread trimming: See 5.5
7		Enter or exit the interface of Parameter
8		Confirm operation or Save value
9		Switch "ABCD" or "EFGH"
10		Increase value
11		Decrease value

5. Operation

5.1 Setup Parameter

5.1.1 Modify Value

Default Interface: Press will be into select parameter interface.

Select Parameter Interface: Press A+/- to select type.

Generally, you can select S/T/A, if you press for 1 second or more when power on, you can select S/T/A/D/O after display "O EN". Press C+/- and D+/- to select index. Press will be into modifying value interface. Press will be return Default Interface.

Modifying Value Interface: Press to modify value or press to recall the default value. Press to confirm and save or press to repeal change, and return Select Parameter

Interface.

5.1.2 Parameter Solidifying

If you want to **change** parameter's **default value**: Select the parameter index, press for 1 second or more, after "SD OK" displaying, the default value has been changed.

Reset to defaults: Set **O17** to "1", then restart and display "INIT". Display "OK" after finished.

5.1.3 Reset to Factory Defaults

One way: Set **O51** to "1", then restart and display "INIT". Display "OK" after finished.

Another way: Press for 1 second or more when power on, display "INIT". Display "OK" after finished.

5.1.4 Encrypt the Parameter Interface

First change **O27** to set password then set **O15** to "1". After this, accessing to parameter interface will be in password interface firstly, input the correct password and press to confirm.

5.2 Set Sewing Mode

Press select LED side key: Top LED set Continuous Backtack, bottom LED set Fixed Stitch.

5.2.1 Sewing Continuous Backtack Stitches

Press select LED side display area: Top LED illuminates and the number of stitches (1~15) for A, B, C and D are displayed. Bottom LED illuminates and the number of segments (1~15) for A.

5.2.2 Sewing Fixed Stitches

Every segments can set own backtack, stitches and thread trimming.

Press select LED side display area: Top LED illuminates and the number of backtack stitches (1~15) for A, B, C and D are displayed. Bottom LED illuminates and the number of segments (1~35) for A, the number of stitches (1~99) of current segment for C and D. After one segment sewing finished, automatic display next segment.

Set the maximum segment: if you need N segments, please set the number of stitches of the segment N+1 to 0.

Set automatic sewing: Set A02 to 1, turn of the automatic sewing function, the Fixed Stitches are sewn simply by depressing the treadle once without needing to depress it continuously.

5.3 Set Needle Up/Down

Press select Needle Up/Down, when the LED is illuminated, the needle bar stops in the up position, otherwise the needle bar stops in the down position.

5.4 Set Slow Start

Set A21 to "1", the first N stitches sewing after the thread is trimmed are sewn at lower speed. Set O01 to "the first N stitches", Set S08 to "lower speed".

5.5 Set Thread Trimming

Press change LED side key: when the LED is illuminated, the thread is trimming automatically after sewn.

5.6 Set Foot Lifter

Set A09 to "1", enable foot lift.

Set A14 to "1", the foot lifter will lift automatically when stop.

Set A15 to "1", the foot lifter will lift automatically after

trimming.

5.7 Set Clamp (or Wiper)

Press change LED side key: when the LED is illuminated, enable Clamp (or wiper).

5.8 Adjust the Backtack

5.8.1 Adjusting of RVE. SOL. Action Time (T01)

For Start/End Backtack or Continuous Backtack, if unbalanced situation is appeared during reverse direction to natural direction, please correct it as below:

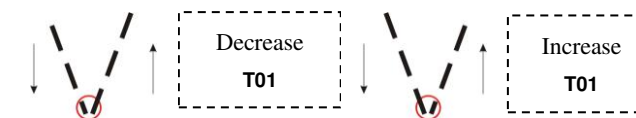

5.8.2 Adjusting of RVE. SOL. release time (T02)

For Start/End Backtack or Continuous Backtack, if unbalanced situation is appeared during reverse direction to natural direction, please correct it as below:

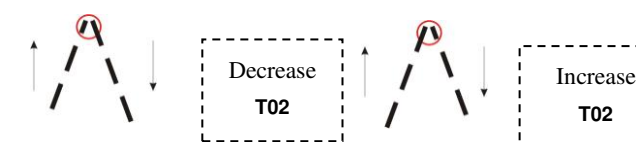

5.9 The Function of Input1/Input2 Button

Buttons are multi-function. A04 set input1, A05 set input2.

- 0 - Reverse only
- 1 - Positioning the needle up/down only
- 2 - Correct stitches only
- 3 - Positioning the needle up/down when stop, reverse when sewing
- 4 - Correct stitches when stop, reverse when sewing
- 5 - Correct stitches and reverse when stop, reverse when sewing
- 6 - reserved
- 7 - End Backtack and thread trimming before thread trimming, auto-lifter after thread trimming.
- 8 - Auto-lifter: Up lift when press the button, down lift when press the button again.

5.10 Safety Switch

Set O31 to "1", if turn up the Machine head, can't sew and display "CARE".

5.11 Automatically Move to Up Position

Set A18 to "1", the machine will move to up position and stop automatically as power on.

5.12 Counting the Product Quantity

Set A11 to "1", press for 1 second or more to turn off all LED side display area. The counter for A, B, C and D are displayed.

Press for 1 second or more will be into collect process interface. A displays "L", B, C and D display the number of stitches of process. It record the number of stitches and the number of trimming times. Finished collect, press for 1 second or more return Sewing Interface.

If sewn the number stitches more than the number of stitches

collected 90%, and the number of trimming times more than collected, the counter add 1.

Press "A-" for 1 second or more, clear counter.

5.13 The Lower Thread Counter



The lower thread counter can be used to let you know approximately how much lower thread is remaining.

Set A12 to "1" enable the counter. Press  for 1 second or more, illuminate all LED side display area, remain thread for A B C and D are displayed.

Press  for 1 second or more, the lower thread counter display will show the initial value which was set previously.

Press , set the initial value (1~9999).

The counter reduces by 1 for every 10 stitches sewn. If the counter less than 1, the display area will warning and buzzer sounds for 3 times. After thread trimming, will not start up again.

Press  the warning will disappear and sewing will be possible, the counter reduces continue. Press  again, the display will return to the initial value.

6. General Parameter Table (part)

6.1 Speed Parameter

SN	Range(rpm)	Description
S01	500~5000	Maximum speed
S02	150~500	Minimum speed
S03	500~2500	Speed of Start Backtack
S04	500~2500	Speed of End Backtack
S05	500~2500	Speed of Continuous Backtack
S06	500~5000	Speed of Fixed Stitch
S07	150~300	Speed of Thread Trimming
S08	200~500	Speed of Slow Start

6.2 Time Parameter

SN	Range(ms)	Description
T01	1~200	Action time of the RVS SOL .
T02	1~200	Release time of the RVS SOL .
T03	1~200	Timing before act the Wiper SOL .
T04	1~200	Timing for act the Wiper SOL .
T05	1~500	Timing before act the Foot Lifter SOL .
T06	1~500	Timing before release Foot Lifter SOL .
T07	1~999	Timing of act the Foot Lifter SOL with whole output.
T08	1~999	Timing of act the RVS SOL with whole output.
T09	1~1000	Timing of judge the Safety Switch .
T10	1~200	The pedal will be greater sensitive when the value is smaller.

6.3 Function Parameter

SN	Range	Description
A01	0~1	Needle Up/Down , see 5.3
A02	0~1	Fixed Stitches automatic sewing, see 5.2.2
A03	0~1	Needle Up/Down of Correct Stitches: 0 - random, 1 - A01
A04	0~8	Input1 function, see 5.9

A05	0~8	Input2 function, see 5.9
A06	0~1	Thread trimming
A08	0~1	Wiper(must set A10 to "0")
A09	0~1	Foot Lifter
A10	0~1	Clamp
A11	0~1	Counting the product quantity, see 5.12
A12	0~1	Lower thread counter, see 5.13
A13	0~1	After trimming, pullback to Needle Top.
A14	0~1	The Foot Lifter will lift automatically when stop, see 5.6
A15	0~1	The Foot Lifter will lift automatically after trimming, see 5.6
A16	0~1	In Fix Stitches. If A02 was set to "1", the next segment will sew automatically after the Start Backtack.
A17	0~1	In Fix Stitches. If A02 was set to "1", the End Backtack and thread trimming will do automatically after the last segment.
A18	0~1	The machine will move to Needle Up and stop automatically as power on.
A19	0~2	Function of pedal back -1 : 0 - neutral position, 1 - Foot Lifter, 2-thread trimming
A21	0~1	Slow Start , see 5.4

6.4 Degree Parameter



SN	Range	Description
D01	0~359°	Needle Up degree.
D02	0~359°	Needle Down degree.
D03	0~359°	Trimmer act degree.
D04	0~359°	Trimmer release degree.
D05	0~359°	Reverse act degree.
D06	0~359°	Reverse release degree.
D07	0~359°	Clamp act degree.
D08	0~359°	Clamp release degree.
D09	0~359°	Reverse act degree(RVS.SW)
D10	0~359°	Reverse release degree(RVS.SW)
D11	0~359°	Reverse forbidden act degree(RVS.SW)
D12	0~359°	Reverse allow act degree(RVS.SW)

6.5 Special function parameter

SN	Range	Description
O01	1~10	The number of stitches of slow start , see 5.4
O05	1~10	The duty of Foot Lifter SOL
O06	0~1	The foot lifter SOL will be released automatically after the time desired(O07)
O07	5~30s	"The time desired" of O06
O09	1~10	The duty of RVS SOL
O10	0~1	The RVS SOL will be released automatically after the time desired(O11)
O11	5~30s	"The time desired" of O10
O15	0~1	Encrypt the parameter interface, see 5.1.4
O17	0~1	Reset parameter to defaults , see 5.1.2

O23	1~60s	The running time of aging test.
O24	1~60s	The idle time of aging test.
O25	1~720h	The total time of aging test.
O26	0~2	Set to "1/2" active the aging test.
O27	0~9999	Password , see 5.1.4
O31	0~1	Safety switch
O32	0~1	Polarity of safety switch
O42	0~1	Foot Lifter when clamping.
O48	1~10	The duty of clamp SOL.
O51	0~1	Reset parameter to Factory Defaults, see 5.1.3
O53	1~10	The duty1 of foot lifter SOL when clamping.
O54	1~10	The duty2 of foot lifter SOL when clamping.
O55	1~10	The duty3 of foot lifter SOL when clamping.
O56	0~4095	Pedal input MAX value : value ≥ O57
O57	0~4095	Pedal input dividing value of high speed and low speed : O56 ≥ value ≥ O58
O58	0~4095	Pedal input dividing value of low speed and Balance : O57 ≥ value ≥ O59
O59	0~4095	Pedal input dividing value of Balance and Foot lifter : O58 ≥ value ≥ O60
O60	0~4095	Pedal input dividing value of Foot lifter and Trimming : O59 ≥ value ≥ O61
O61	0~4095	Pedal input MIN value : value ≤ O60
O62	0~250	Pedal loop value
O63	0~5	Pedal mode: 0-linear;1-polyline;2-curve(slow → quick);3-curve(quick → slow); 4-S curve(slow → quick → slow); 5-S curve(quick → slow → quick)
O64	500~5000	The speed of knee of polyline
O65	0~4095	The value of knee of polyline: O56 ≥ value ≥ O57
O66	1~10	The period of Foot Lifter SOL(ms)
O67	1~10	The period of RVS SOL(ms)
O68	0~1	Mode of the End Backtack: 0- Stop first, then act RVS SOL; 1-Act RVS SOL when running
O69	0~1	Mode of correct stitches: 0-before trimming only; 1-only if stop
O72	0~10	Add torque when low speed

7. Signal Checking

Press  for 1 second or more when power on, display "TEST". Press  to increase SN, press  to decrease SN.

7.1 Pedal: 2 modes, press A+ select

(1) Display the value of pedal;

(2) Display the different pedal position as below:

Display	Meanings	Descriptions
HS02~99	High speed	The second segment forward
LS01	Low speed	The first segment forward
BL--	Balance	Default
FP--	Foot lifter	The first segment backward

TM--	Trimming	The second segment of backward
ERRO	Fault	Pedal fault or disconnected

7.2 Synchronizer: Turn the hand wheel by hand equably, display "UP 1" or "UP".

7.3 Switch: B - Input1; C - Input2; D - Safety Switch

7.4 Encoder signal of motor: Turn the hand wheel by hand equably, display the encode count of motor, the error is ±5 normally.

7.5 Solenoid: display "TRWF", press  act solenoid. T - trimmer, R - RVS, W - wiper(or clamp), F - Foot Lifter

7.6 Version of software: v100, e.g. the version is v 1.00

7.7 Date of software: A displays year, D-2013, E-2014, and so on. B displays month, A-October, B-November, C-December. CD display day. E.g.: "D815" - 2013.8.15

7.8 AC power

7.9 BUS power

7.10 Phase A current, Range is 2050±50

7.11 Phase B current, Range is 2050±50

8. Setup zero point

Press  for 1 second or more when power on, display "ZERO". Turn hand wheel equably, display the current degree.

Turn hand wheel to top dead center, then press  and display "SET" to set zero degree point.

9. Measurement of Error and Warning

code	Causation	Measurement
E 01	Voltage is too high	Check the AC power.
E 03	Voltage is too high	Check the AC power.
E 06	Current is overload	Check the load.
E 08	Load is too heavy	Check the load.
E 09	Motor error	Check motor wire
E 10	Synchronizer error	Check synchronizer, see 7.2.
PEDL	Pedal warning	Release the pedal.
CARE	Safety SW warning	Check Safety SW., see 5.10.
KEY1	Input1 warning	Check Input1
KEY2	Input2 warning	Check Input1

Appendix: 7-segment Display Characters Compare Table

0	1	2	3	4	5	6	7	8	9
A	B	C	D	E	F	G	H	I	J
K	L	M	N	O	P	Q	R	S	T
U	V	W	X	Y	Z				
U	u	8	11	P	E				